

**3/2-, 5/2- and 5/3 Directional control valves**  
**Actuation: electromagnetic**  
**Indirectly controlled soft seal spool valves**  
**Port size: G 1/4, 1/4 NPT**  
**NAMUR Interface**

**For single and double operated actuators**  
**Exhaust air recirculation (3 way function)**  
**Crossover-free switching, switch-over function guaranteed even with small cross section air supply**  
**Restposition in the event of power failure provided (monostable design)**

**3/2 or 5/2 way function in one valve**

**Manual override with detent**

**Compact design**

**Simple design of soft seal spool system**

**Easily interchangeable solenoid**

**The solenoid valves are applicable in the protection class EEx m and EEx ia, for zones 1, 2 (gases) ATEX cat.II 2 G, EEx nA, for zones 2 (gases), 22 (dust) ATEX cat.II 3 GD**



### Technical data

Medium:  
 Filtered, non-lubricated and dry compressed air \*1)

Operation:  
 Solenoid, indirectly controlled

Flow direction:  
 Fixed

Mounting position:  
 Optional

Nominal diameter:  
 6 mm

Port size:  
 1: G 1/4, 1/4 NPT; 3 and 5: G 1/8, 1/8-NPT

Electrical connection:  
 See solenoid table

Operating pressure:  
 Max. 8 bar

Temperature:  
 Valve: -25\* to +50°C

Solenoid: see solenoid table

\*Please consult our technical service for use below +2°C.

### Materials:

Housing: Aluminium anodized

Pilot flange: Plastic (PBT)

Seals: NBR (Perbunan)

\*1) Oil recommendation: Shell Hydrol DO 32, ESSO Febis K 32 (as of July 1992) or comparable oils with DVI-values < 8 (DIN 53521) and ISO viscosity class 32-46 (DIN 51519).

### Ordering information

5/2 directional control valve, port size G 1/4, solenoid 24 V DC, with connector DIN EN 175 301-803 form A, Protection class IP 65  
**Type: 9710000.3036.024.00**  
**connector: 0570275**

### Connectors

See data sheet N/en 7.7.002

3/2

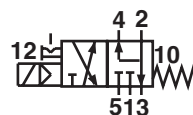

5/2

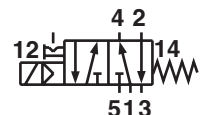

3/2

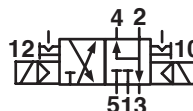

5/2

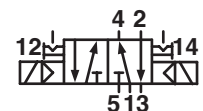

5/3

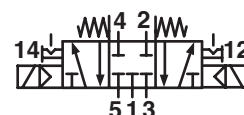

### 3/2, 5/2 and 5/3 directional valves, standard design

5/2 way or 3/2 way function (see conversion instructions page 6)

Symbol	Type	port size			Actuation	Operation pressure (bar)	Flow (l/min)	Weight (kg)	Dimensions No.
		1	3, 5	2, 4					
	9710000*	G 1/4	G 1/8	Flange	Solenoid/Spring	2 ... 8	750	0,25	1
	9710010*	1/4 NPT	1/8 NPT	Flange					
	9711000*	G 1/4	G 1/8	Flange	Solenoid/Solenoid	2 ... 8	750	0,35	2
	9711010*	1/4 NPT	1/8 NPT	Flange					
	9712000*	G 1/4	G 1/8	Flange	Solenoid/Solenoid mid position APB	2 ... 8	500	0,40	3
	9712010*	1/4 NPT	1/8 NPT	Flange					

\* When ordering please indicate solenoid, voltage and current type (frequency).  
 Outside free of nonferrous metals  
 Valve function: APB = All Ports Blocked

### Solenoid actuators

Type	Power consumption 24 V DC (W)	230 V AC (VA)	Ex Protection Categorie	Protection class	Temperature Ambient Fluid (°C)	Weight (kg)	Dimensions No.	Circuit diagram No.	
	3036	1,6	3,5	-	IP 65 (with connector) DIN EN 175301-803 Form A *6)	-40 ... +50	0,090	5	1
	3046	2	-	II3G II3D	EEx nA II T5 IP65 T 95°C with connector DIN EN 175301-803 Form A	-15 ... +50	0,300	5	1
	3047	-	4,0	II3G II3D	EEx nA II T5 IP65 T 95°C with connector DIN EN 175301-803 Form A	-15 ... +50	0,300	5	8
	3062 *3)	2,7	-	II2G	EEx m II T5 Stranded wire, 3 m long	-20 ... +50	0,300	6	1
	3063 *3)	-	2,1	II2G	EEx m II T5 Stranded wire, 3 m long	-20 ... +50	0,300	6	8
	3071	2,7	-	-	IP 66 Connection M12x1 DIN EN 60947-5-2	-10 ... +50	0,110	7	8

Standard voltages 24 V DC, 230 V AC. Other voltages on request.  
 For intrinsically safe circuits, protection class EEx ia IIC T6

\*3) Certificate of Conformity PTB No. PTB 03 ATEX 2015X  
 \*6) Connector is not indicated in delivery; Required connector 0570275

**3/2, 5/2 and 5/3 directional valves for minimal electrical power, incl. EEx i**  
 5/2 way or 3/2 way function (see conversion instructions page 6)

Symbol	Type	port size			Actuation	Operation pressure (bar)	Flow (l/min)	Weight (kg)	Dimensions No.
		1	3, 5	2, 4					
	9710002*	G 1/4	G 1/8	Flange	Solenoid/Spring	2 ... 8	750	0,25	1
	9710012*	1/4 NPT	1/8 NPT	Flange					
	9711002*	G 1/4	G 1/8	Flange	Solenoid/Solenoid	2 ... 8	750	0,35	2
	9711012*	1/4 NPT	1/8 NPT	Flange					
	9712002*	G 1/4	G 1/8	Flange	Solenoid/Solenoid	2 ... 8	500	0,40	3
	9712012*	1/4 NPT	1/8 NPT	Flange					

\* When ordering please indicate solenoid, voltage and current type (frequency).  
 Outside free of nonferrous metals  
 Valve function: APB = All Ports Blocked

**Solenoid actuators**

Type	Power consumption		Rated current at		Ex Protection Categorie	Protection class	Temperature Ambient/ Fluid (°C)	Weight (kg)	Dimensions No.	Circuit diagram No.
	24 V DC (W)	230 V AC (VA)	24 V DC (W)	230 V AC (VA)						
	3050	1,7	-	-	-	IP 65 (with connector) DIN EN 175301-803 Form B *6)	-40 ... +50	0,054	4	1
	3034	0,7	0,7 *2)	-	-	IP 65 (with connector) *6) DIN EN 175301-803 Form A	-40 ... +50	0,090	5	1
	3046	2	-	-	-	II3G II3D EEx nA II T5 IP65 T 95°C with connector	-15 ... +50	0,300	5	1
	3062 *3)	2,7	-	115	-	II2G EEx m II T5 Connector with 3 m cable	-20 ... +50	0,300	6	1
	3063 *3)	-	2,1 *2)	-	9 *2)	II2G EEx m II T5 Connector with 3 m cable	-20 ... +50	0,300	6	8
	3071	2,7	-	115	-	IP 66 Connection M12x1 DIN EN 60947-5-2	-10 ... +50	0,110	7	8

Standard voltages 24 V DC, 230 V AC. Other voltages on request. Design acc. to VDE 0580, EN 50014/50028. 100% duty cycle.

**For intrinsically safe circuits, protection class EEx ia IIC T6/T4**

Type	Nom. resistance R <sub>n</sub> coil (Δ)	Required switching current (mA)	Resistance R <sub>w50</sub> coil	Required voltage at terminal R <sub>w50</sub>	Ambient temperature (°C)	Fluid temperature max. (°C)	Weight (kg)	Dimensions No.	Circuit diagram No.	
	3039 *4)	275	37	330	12,3	T6 -40 ... +80 T4 -40 ... +80	T6 +70 T4 +85	0,83	8	13

When selecting an intrinsically safe power supply, the permissible maximum values according to the Certificate of Conformity should be taken in account. On the other hand, the low effective inductivity and capacity can be ignored.

\*2) Valves can be operated with DC only. For 230 V AC application please use 206 V DC coil together with recifier plug 0663303





\*3) Certificate of Conformity PTB No. PTB 03 ATEX 2015X

\*4) Certificate of Conformity PTB 03 ATEX 2134 PTP 03 IEC 2166, CSA -Certificate No. LR 51090-4, FM approved.

Required connector acc. to DIN EN 17031-801 form A or ISO 4400. Installation acc. to requirements of FM and CSA. Connector is not indicated in delivery.

\*6) Connector is not indicated in delivery; required connector for DC: type 0680003 Form B, 0570275 Form A.

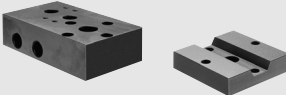
Accessories

Silencer	Connectors	Flange plate	Yoke
			
0014500 (G1/8) *1)	0570275 form A 0663303 with rectifier 0680003 form B	0612790 NAMUR single connection plate 0612791 NAMUR-rip use in combination with 0612790 (Alu)	0540593

\*1) For indoors use

Basic dimensions for valves

①, ②

③

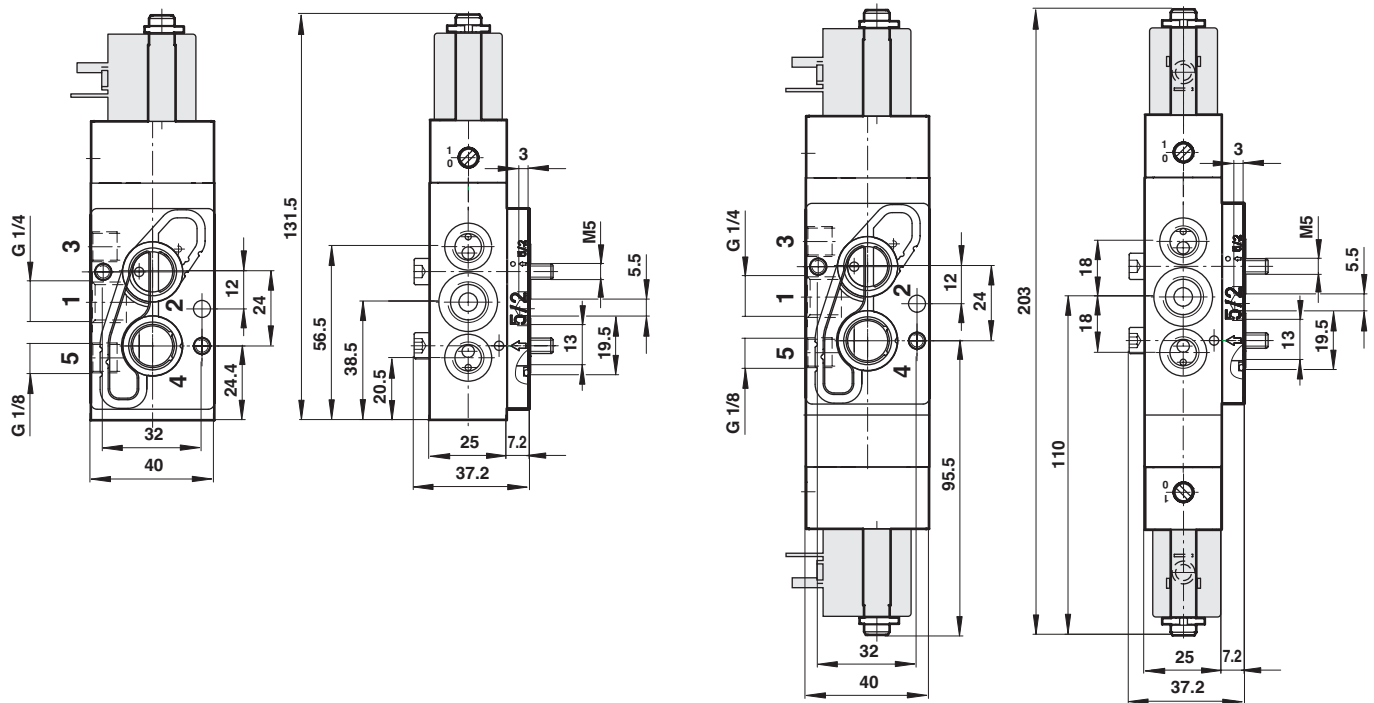

**Basic dimensions for solenoid operators**

④

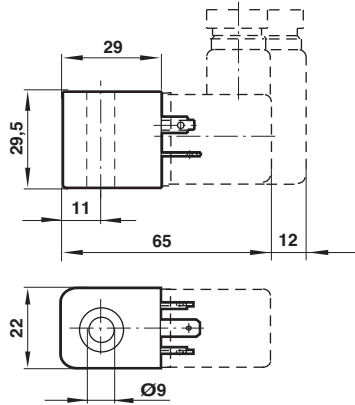

⑤

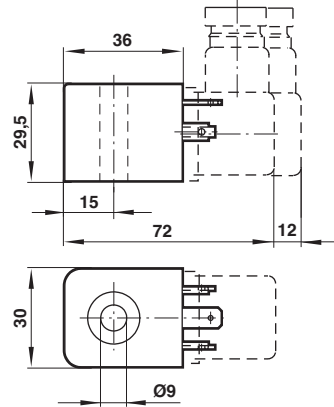

⑥

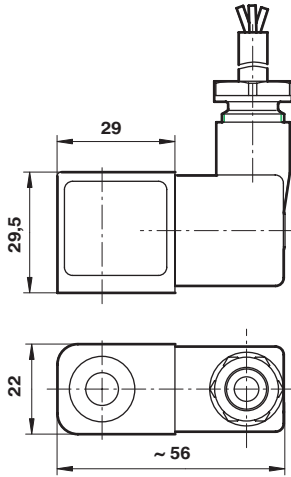

⑦

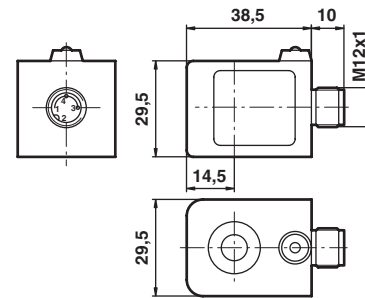

⑧

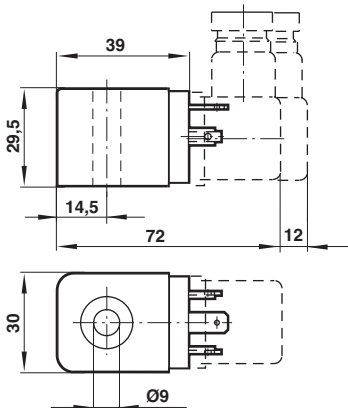

**Circuit diagrams**

①

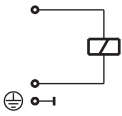

⑧

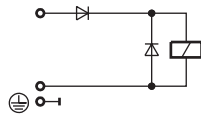

⑬

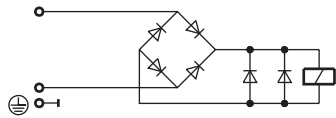

**NAMUR hole pattern**

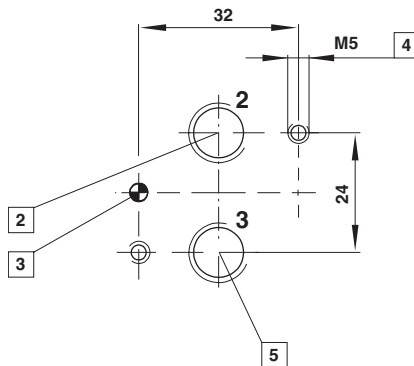

2	Port 2 (A)
3	Coding stud threaded
4	M5 (10 deep)
5	Port 3 (R)

**Conversion instructions of 5/2 into 3/2 way function**

**5/2 way function (original mode of supply)**

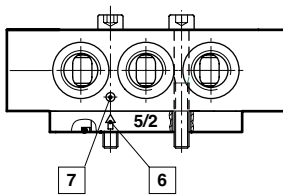

**3/2 way function**

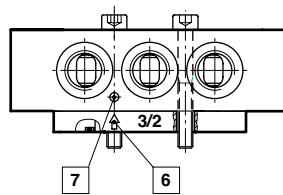

3/2 resp. 5/2 way function can be achieved just by swapping enclosed adaptor plates. Make sure Marker and Arrow do match as shown on above drawing. Original mode of supply: 5/2 function.

6	Arrow
7	Marker

**Warning**

These products are intended for use in industrial compressed air systems only. Do not use these products where pressures and temperatures can exceed those listed under 'Technical Data'. Before using these products with fluids other than those specified, for non-industrial applications, life-support systems, or other applications not within published specifications, consult NORGREN. Through misuse, age, or malfunction, components used in fluid power systems can fail in various modes. The system designer is warned to consider the failure modes of all component parts used in fluid power

systems and to provide adequate safeguards to prevent personal injury or damage to equipment in the event of such failure.

**System designers must provide a warning to end users in the system instructional manual if protection against a failure mode cannot be adequately provided.**

System designers and end users are cautioned to review specific warnings found in instruction sheets packed and shipped with these products where applicable.